

## LIRE LED Inset Runway Edge Light

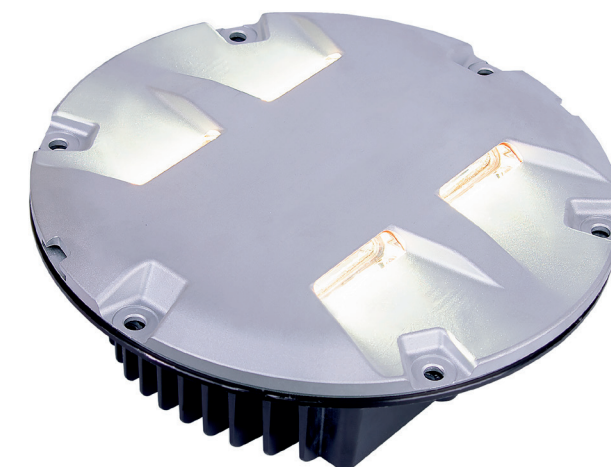

تهران، بزرگراه شیخ فضل ا... نوری، خیابان سازمان آب، خیابان حاجی پور امیر، کوچه مهدی، پلاک ۱  
No.1, Mahdi Alley, Haji Pour Amir St., Sazman Aab Ave., Sheikh Fazlollah Nouri Highway, Tehran, IRAN

Email info@tmb-co.com | فکس ۰۲۱۸۸۲۶۰۷۰۷ | تلفن ۰۲۱۸۷۷۴۰ | کدپستی ۱۴۵۴۶۴۳۶۸۵  
Web www.tmb-co.com | Fax 98 218826 0707 | Tel 98 21 87740 | P.O Box 1454643685



- No optical adjustment after LED module or prism replacement
- Valve for watertightness test after overhaul
- Operating with any topology of CCRs designed in compliance with IEC or FAA requirements

\* For monitored fixtures, isolation transformer max size: 200VA

### ▶ PERFORMANCES

- The electronic is strong-built and highly resistant to shock and vibration
- Automatic adaptation to the frequency of the supply current
- A surge protection device is provided in the electronics as required by the FAA "Engineering Briefing No.67"
- Immediate detection of an internal fault
- 6.35 mm protrusion strongly reduces vibrations to aircrafts and to light itself, increasing its lifetime
- Dome smooth outer profile makes the light less sensitive to snowplough blades
- Bidirectional or unidirectional, 12" dia.
- Drop-forged dome and cast aluminium lower cover make the fitting sturdy, but lightweight too for ease handling in the field
- Light output practically not affected by heavy rainfall thanks to the shallow channel in front of the prism windows
- O-Ring placed outside the dome to avoid dirt deposits between light and base
- Protection degree: IP68
- Temperature range: -45°C to +55°C

### ▶ INSTALLATION

- Suitable for 12" dia. bases
- Specific tools available for easy and precise installation

### ▶ COMPLIANCES

- ICAO** Annex 14 - Volume I Fig. A2-9, A2-10
- EASA** CS-ADR-DSN, Book 1, Fig. U-13, U-14
- FAA** L-850C(L) AC150/5345-46 and EB No.67
- IEC** TS 61827
- NATO** STANAG 3316
- CAA** CAP 168
- IAAE** TP312
- CASA** Manual of Standards Part 139

### ▶ APPLICATIONS

Runways edge for ICAO CAT I, II and III, FAA and military runways

### ▶ BENEFITS

- 60000 hours LED rated life at full intensity, but over 100000 hours in field operating conditions
- In new installation, LED lights mean lower loads, lower size of CCRs and transformers, thus low life cycle costs
- The light output is variable like a traditional halogen lamp, as indicated by the FAA "Engineering Briefing No.67"
- Colour emitted directly by LEDs : absence of coloured filters ensures no energy losses and no colour shifts
- Fully compatible with existing AFL infrastructure\*
- Designed with simplicity allowing longer maintenance intervals and fewer spare parts
- No use of sealant to fix the prisms in the dome thanks to customized gaskets, making their replacement quick and easy



**MAIN COMPONENTS OF THE LIGHT UNIT**

- 1 : Dome ( Upper Cover )
- 2 : O-Ring for dome (internal)
- 3 : O-Ring for lower cover
- 4 : Prism Gasket
- 5 : Prism
- 6 : Prism holder gasket
- 7 : Mounting plate
- 8 : LED module with accessories
- 9 : Optical Lens
- 10 : Heat Sink
- 11 : Bracket
- 12 : Lower cover with electronic
- 13 : Valve for watertightness test
- 14 : Plug

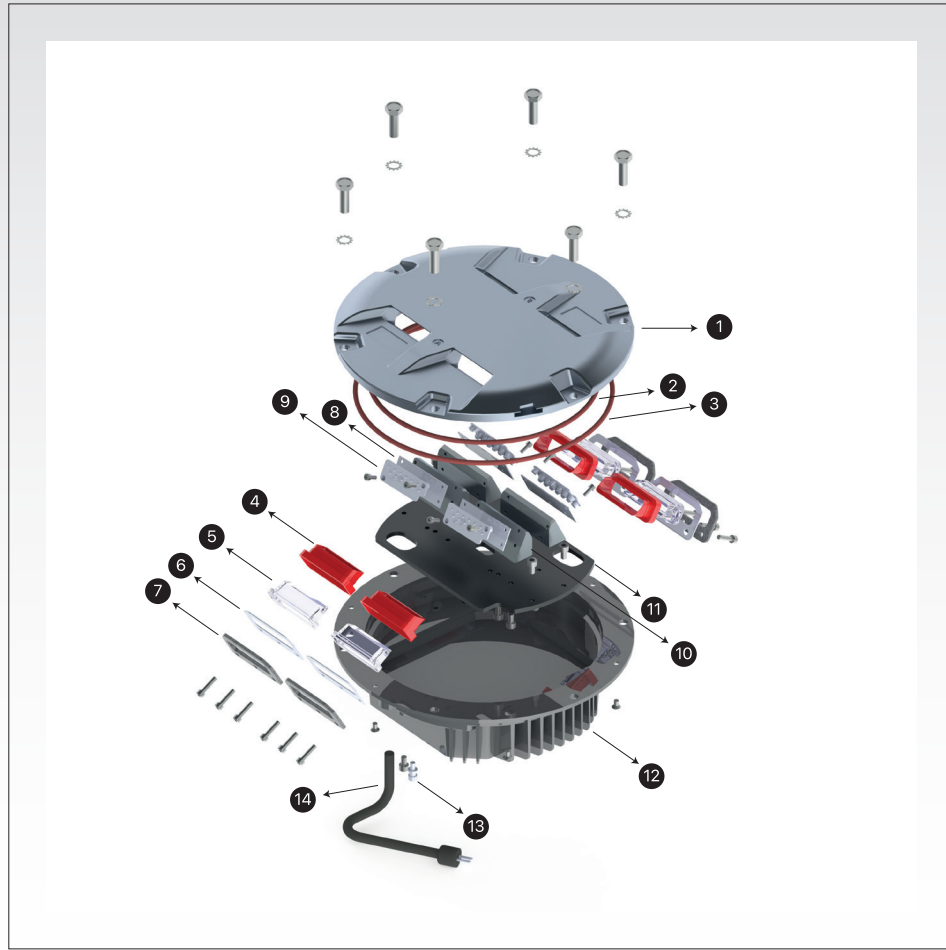

**PHOMETRIC PERFORMANCE**

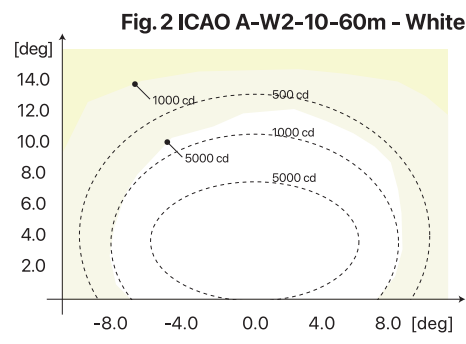
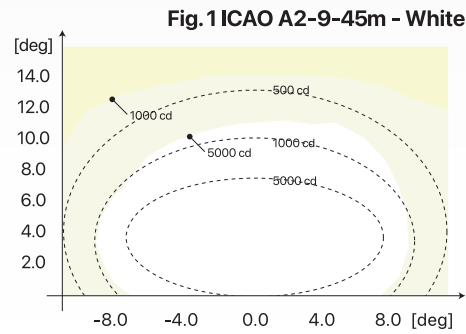

POWER CONSUMPTION*		
Electrical System	1 Plug	2 Plugs
Unidirectional (w/o Arctic Kit)	31 VA	-
Unidirectional (with Arctic Kit)	71 VA	-
Bidirectional (w/o Arctic Kit)	65 VA	62 VA
Bidirectional (with Arctic Kit)	105 VA	142 VA

\* Measured at 6.6 A and referred to the highest consumption configuration

POWER FACTOR		
Input Step	2.8A	6.6A
Power Factor	0.96	0.98

SHIPPING WEIGHTS & VOLUMES		
	Light Unit	Shallow Base
Weight(kg)	9.1	7.3
Volume(m³)	0.022	0.022

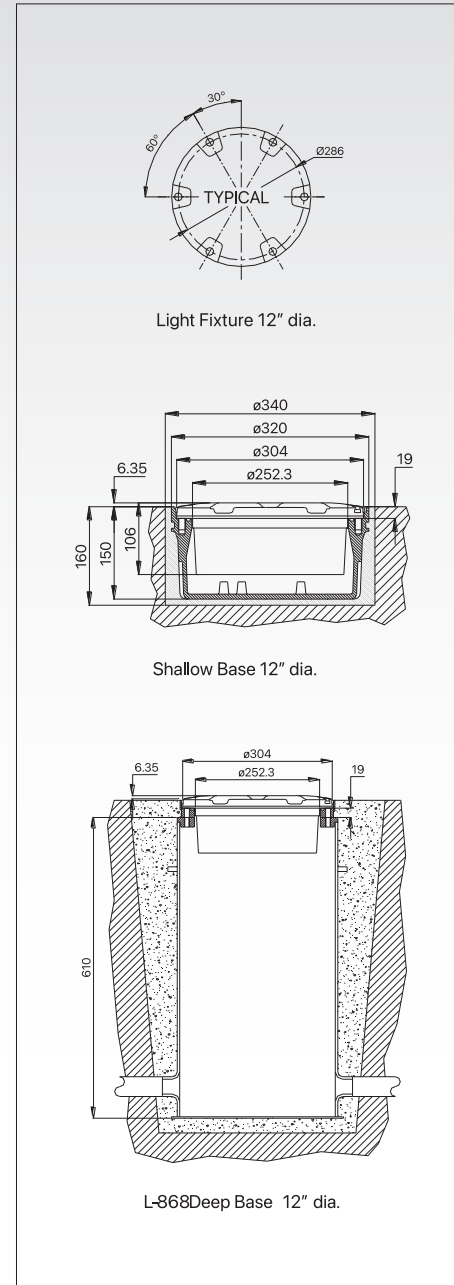

**LIRE I WY 2P M A**

- Basic P/N**
- Compliance**  
I = ICAO
- Colour(Side L)/(Side R)**  
W = White  
Y = Yellow  
R = Red  
M = Blank (unidirectional dome)
- Arctic Kit**  
O = Without Arctic Kit  
A = With Arctic Kit
- Monitoring**  
O = Without Monitoring  
M = With Monitoring
- Cable and connectors**  
1P = One Plug  
2P = Two Plugs

\* The beam aiming is not field adjustable

